





UltraView UVC-6120-1 Digital WDR Camera User Manual

Copyright	© 2012 UTC Fire & Security. All rights reserved.
Trademarks and patents	The TruVision and Interlogix names and logo are trademarks of UTC Fire & Security. Other trade names used in this document may be trademarks or registered trademarks of the manufacturers or vendors of the respective products.
Manufacturer	UTC Fire & Security Americas Corporation, Inc. 2955 Red Hill Avenue, Costa Mesa, CA 92626-5923, USA Authorized EU manufacturing representative: UTC Fire & Security B.V. Kelvinstraat 7, 6003 DH Weert, The Netherlands
Certification	  N4131
FCC compliance	Class A: This equipment has been tested and found to comply with the limits for a Class A digital device, pursuant to part 15 of the FCC Rules. These limits are designed to provide reasonable protection against harmful interference when the equipment is operated in a commercial environment. This equipment generates, uses, and can radiate radio frequency energy and, if not installed and used in accordance with the instruction manual, may cause harmful interference to radio communications. Operation of this equipment in a residential area is likely to cause harmful interference in which case the user will be required to correct the interference at his own expense.
ACMA compliance	Notice! This is a Class A product. In a domestic environment this product may cause radio interference in which case the user may be required to take adequate measures.
European Union directives	12004/108/EC (EMC directive): Hereby, UTC Fire & Security declares that this device is in compliance or with the essential requirements and other relevant provisions of Directive 2004/108/EC 2002/96/EC (WEEE directive): Products marked with this symbol cannot be disposed of as unsorted municipal waste in the European Union. For proper recycling, return this product to your local supplier upon the purchase of equivalent new equipment, or dispose of it at designated collection points. For more information see: www.recyclethis.info .
Contact information	For contact information, see www.utcfireandsecurity.com or www.utcfssecurityproducts.eu .



Content

Product overview	2
Package Contents	2
Features	2
User guidelines	2
Product description	3
OSD control pad	4
Installation	5
Connect the video cable	5
Attach the lens	5
Connect the power cable	6
Programming	8
Access the Main menu	8
General menu	9
AE/WDR/BLC menu	9
WB mode menu	10
D/N mode menu	11
Motion alarm menu	12
Privacy menu	12
Picture adjustment menu	13
Reset camera	14
Specifications	14
Dimensions	14
Menu Map	15

Product overview

The UVC-6120-1- XX color video camera uses a digital signal processor (DSP) to process video signals. The video camera includes a microcontroller to provide high-quality images with high-color reproduction and sharp pictures.

Package Contents

The package contains the following:

- Box camera
- Dual power terminal block with screw and anchor
- Hex wrench

Features

The camera includes the following features:

- Exview HAD II (hole accumulated diode) technology with 480,000 pixels NTSC (570,000 PAL)
- LSI (large scale integration) digital processors, producing 650 lines of horizontal resolution
- Smart digital control automatic BLC (backlight compensation)
- Digital WDR (wide dynamic range)
- Advanced auto exposure system for both fixed iris and auto iris lenses to optimize the amount of light
- Internal synchronization
- Eight privacy mask areas to protect privacy concerns
- Advanced OSD (onscreen display) control
- Signal-to-noise ratio better than 52 dB
- Long life and high reliability
- Isolated switching power 12 VDC and 24 VAC

User guidelines

- Program the camera settings as much as possible before mounting the camera. Take appropriate safety precautions while completing programming after installation.
- Always use a 12 VDC or 24 VAC UL listed Class 2 power supply to power the camera.
- Do not use the camera over the temperature range specifications: -10°C to +50°C (14°F to 122°F)

- If the light source where the camera is installed experiences rapid, wide-variations in lighting, the camera may not operate as intended.

WARNING: To reduce the risk of fire or electronic shock, do not expose the camera to rain or moisture and do not remove the cover or back.

Product description

Figure 1: Camera UVC-6120-1-P/N

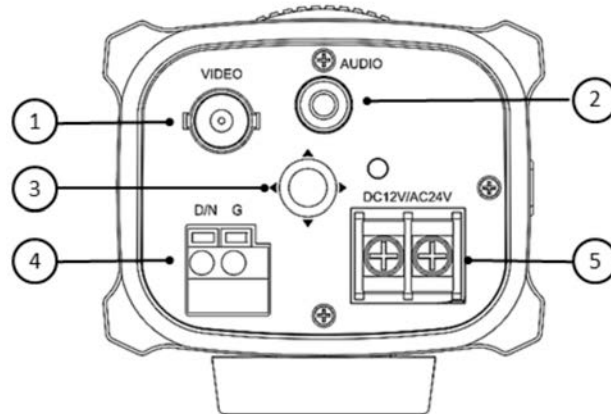

- | | |
|--------------------|-------------------------------|
| 1. Video output | 4. D/N trigger pin |
| 2. Audio output | 5. 12 VDC / 24 VAC dual power |
| 3. OSD control pad | |

Figure 2: Camera UVC-6120-1-P2

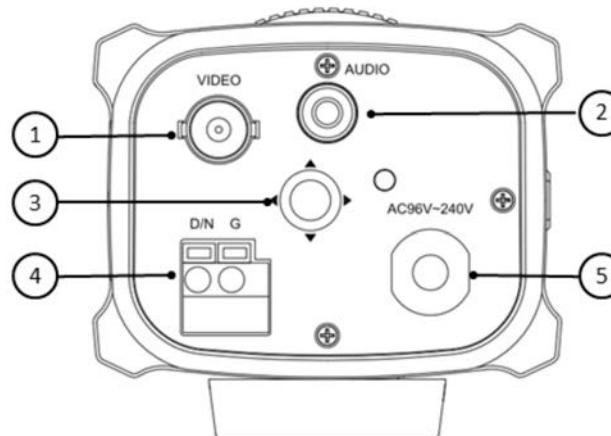

- | | |
|--------------------|--------------------------------|
| 1. Video output | 4. D/N trigger pin |
| 2. Audio output | 5. AC96V/AC240 universal power |
| 3. OSD control pad | |

OSD control pad

The on-screen display (OSD) control pad (see Figure 1) lets you manually control the camera functions. Table 1 below lists the OSD control pad functions and describes their use.

Table 1 Using the OSD control pad

Pad direction	Description
Up	Moves the cursor upward to select an item
Left	Moves the cursor left to select or adjust the parameters of the selected item.
Right	Moves the cursor to the right to select or adjust the parameters of the selected item.
Down	Moves the cursor downward to select an item.
Enter	Press the center of the control pad to display the Main menu. If the selected item has its own menu, press the pad to enter a submenu.

Installation

Please check the package contents and make sure that the device in the package is in good condition and all the assembly parts are included.

To install the camera you will need to prepare the mounting surface, mount the camera, attach the lens, and make cable connections,

Note: Before installing, please ensure that the mounting surface is strong enough to withstand three times the weight of the camera. If the mounting surface is not strong enough, the camera may fall and cause serious damage.

Connect the video cable

Connect a coaxial cable from the camera's BNC connector to a CCTV monitor or video recording device.

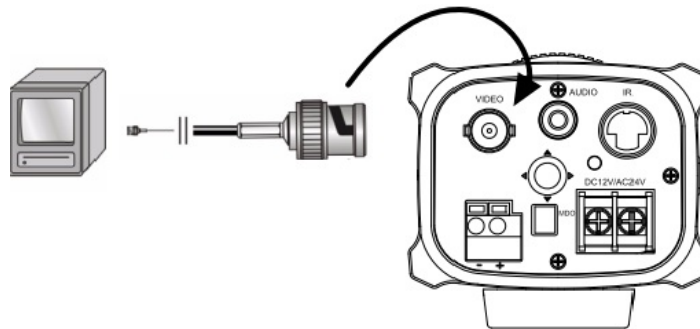

Attach the lens

Refer to the instructions that came with the lens you purchased for complete installation instructions of that lens.

Note: For optimal performance, use an auto iris lens.

Figure 3: Attaching the lens

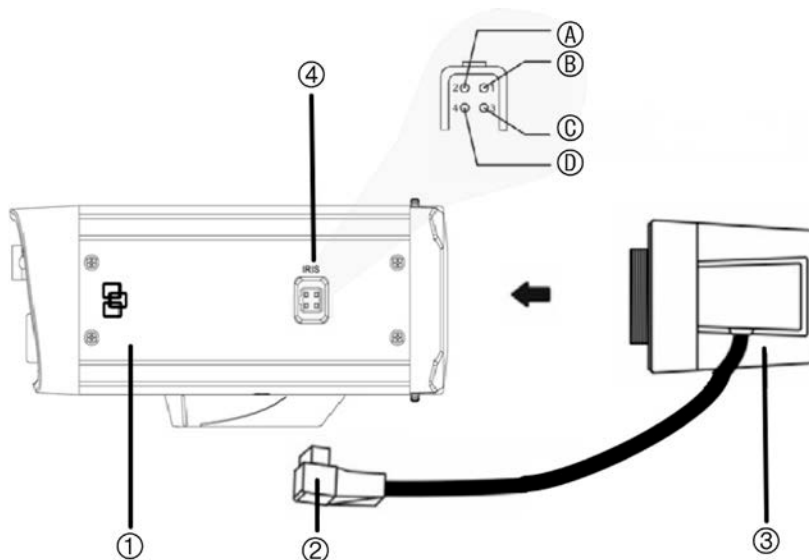

1. Camera
2. Autoiris lens plug
3. Lens (autoiris shown)
4. DC type autoiris lens leads
A. Damping coil (+); B. Damping coil (-);
C. Driving coil (+); D. Driving coil (-)

To attach the lens:

1. Screw the lens clockwise onto the lens mount of the camera.
Note: Please prevent dust from entering between the lens mount and the lens.
2. For optimal performance, please use an auto iris lens. Plug the auto-iris drive cable to the 4-pin interface on the side of the camera.

Connect the power cable

For UVC-6120-1-P/N

1. With a screwdriver, loosen the ~AC24V/DC12V and GND terminal screws on the terminal block.
2. Connect a universal 12 VDC/24 VAC power supply to the terminal block.

Note: The terminal block is not polarity sensitive. Either power lead can be connected to either terminal connector. There is no need for an isolated ground wire. The two power terminals can accept any polarity and any combination of power that equals 12 VDC or 24 VDC.

3. Retighten the terminal screws until snug, ensuring that the power leads are secure.
4. Supply power to the unit by plugging the power supply into a proper source.

Note: The power LED illuminates to show that the camera is receiving power. If it does not illuminate, check the terminal block connections and the power source.

For UVC-6120-1-P2

Connect the power cable of a high voltage camera to either a 230 VAC or a 120 VAC power supply outlet.

Programming

Once the camera hardware has been installed, the camera can then be configured.

Access the Main menu

The Main menu provides access to the camera configuration options. The on-screen display (OSD) is only available in English.

Program the camera by attaching a standard video monitor to the system.

Figure 4: The Main menu

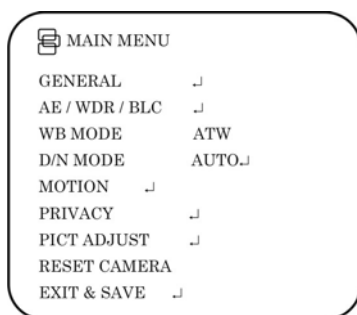

Table 2: Main menu description

Menu item	Description
General	Defines the camera ID, mirror, and digital noise reduction (DNR) set up.
AE/WDR/BLC	Defines the lens type as well as the WDR/BLC, AGC, and flicker set up.
WB mode	Defines the white balance (WB) set up.
D/N mode	Defines the day/night (D/N) set up.
Motion	Defines the motion detection set up.
Privacy	Defines privacy mask set up.
Pict adjust	Defines the image quality functions.
Reset camera	Resets the camera to factory default settings.
Exit & save	Exits the menu and returns to live mode. Saves changes made.

To access the Main menu:

1. Press the OSD control pad (**Enter**) to access the Main menu and its submenus.
2. Push the pad up, down, left and right to move between menu options.
3. Press the OSD control pad to select an option.
4. When in a sub menu, select **Return** to return to the previous menu.
5. To exit the Main menu, move the cursor to **Exit** at the bottom of the screen and press **Enter**. All changes are saved.

General menu

Select the **General** option from the Main menu to enter the General menu.

Figure 5: The General menu

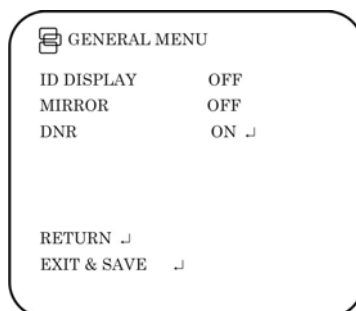

Table 3: General menu

Parameter	Description
ID display	Displays the camera ID on screen. Default option is Off.
Mirror	Flips the camera image so that it is correctly orientated for viewing. Default option is Off.
DNR	Digital noise reduction (DNR) improves the image quality in low light levels. When enabled, select the Y and C filter strength: Press Return to return to the previous menu or Exit & Save to save changes and return to live mode. Default option is On.
Return	Press Enter to return to the previous menu.
Exit & Save	Exits the menu and returns to live mode. Saves changes made.

AE/WDR/BLC menu

Select the **AE/WDR/BLC** option from the Main menu to enter the AE menu.

Figure 6: The AE/WDR/BLC menu

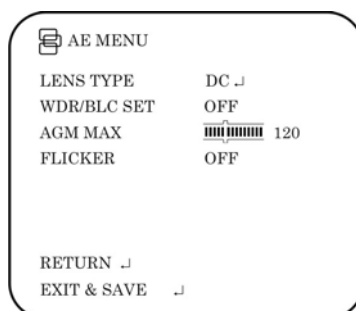

Table 4: AE/WDR/BLC menu

Menu item	Description
Lens type	Defines the lens type used with the camera. Select Fixed or DC . If DC is enabled, select the DC level and shutter speed

Menu item	Description
	from the options shown.
WDR/BLC set	<p>Wide dynamic range (WDR) allows you to see details of objects in shadows or details of objects in bright areas of frames that have high contrast between light and dark areas such as the headlights of a passing car.</p> <p>Backlight compensation (BLC) function improves image quality when the background illumination is high. It prevents the object in the center from appearing too dark.</p> <p>Options are:</p> <ul style="list-style-type: none"> • Off • WDR: Set the luminance level (Low, Middle, High) • BLC fix: set the BLC level (between 1 to 30) and the BLC window.
AGC max	<p>Defines the automatic gain control (AGM).</p> <p>Select a value between 0 and 160.</p>
Flicker	<p>This feature to prevent the strobing effect under certain lighting conditions/shutter speeds.</p> <p>Default option is Off.</p>
Return	Press Enter to return to the previous menu.
Exit & Save	Exits the menu and returns to live mode. Saves changes made.

WB mode menu

White balance (WB) tells the dome camera what the color white looks like. Based on this information, the dome camera will then continue to display all colors correctly even when the color temperature of the scene changes such as from daylight to fluorescent lighting, for example.

Select the **W/B Mode** option from the Main menu to enter the WB Mode menu.

Figure 7: The AE/WDR/BLC menu

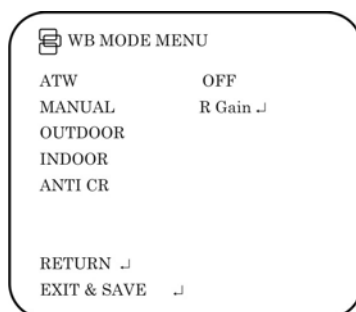

Table 5: AE/WDR/BLC menu

Menu item	Description
ATW	The auto track white balance (ATW) function automatically adjusts the WB in real time as the lighting conditions change. It can be used for both indoor and outdoor locations.
Manual	Manually fix the white balance by adjusting the blue and red gain parameters. Only use this function when there is steady light. Values can be adjusted between -5 and +5.

Menu item	Description
Outdoor	Select this option to optimize the WB for outdoor sunlit applications. The ATW compensates for high color temperature such as daylight.
Indoor	Select this option to optimize the WB for indoor applications. The ATW compensates for low color temperature such as incandescent lighting.
Anti CR	The anti-color rolling mode function minimizes the color changes over long periods caused by very small differences between the flicker frequency of non-inverter fluorescent lights and the drive frequency of the image sensor devices.
Return	Press Enter to return to the previous menu.
Exit & Save	Exits the menu and returns to live mode. Saves changes made.

D/N mode menu

This camera function controls when the dome camera switches to day or night mode. The dome camera produces high-quality color video during the day or when light levels are high. At night or when light levels are low the camera switches monochrome and removes the infrared filter to improve IR sensitivity.

Select the **D/N Mode** option from the Main menu to enter the D/N mode menu.

Table 6: D/N mode menu

Menu item	Description
Auto	<p>When set to Auto Day/Night mode, the camera produces high-quality color video during the day or when light levels are high. It then switches to monochrome and removes the infrared filter to improve IR sensitivity at night or when light levels are low. Set following parameters:</p> <p>Day→Night: Set the threshold level on how dark it should be before switching from Day to Night mode. Lower (Higher) value makes the camera switched from Day to Night at lower (higher) illumination</p> <p>Night→Day: Set the threshold level on how light it should be before switching from Night to Day mode.</p> <p>Delay seconds: This is the time in seconds before Day↔Night switches. A long delay response would be used, for example, to avoid switching from Night to Day mode when car headlights pass in front of the camera.</p> <p>CAUTION: If there is a minimal difference between the Day→Night and Night→Day values, then camera may switch between Day and Night mode repeatedly.</p>
Day	Manually select Day mode only. The camera can only be in Day mode.
Night	Manually select Night mode only. The camera can only be in Night mode.
Ext	Externally triggered D/N switch.
Return	Press Enter to return to the previous menu.
Exit & Save	Exits the menu and returns to live mode. Saves changes made.

Motion alarm menu

A motion detection alarm is an alarm that is triggered when the camera detects a motion. You can define up to four areas on screen where the motion can be detected as well as the level of sensitivity to motion.

Select the **Motion** option from the Main menu to enter the Motion menu.

Figure 8: The Motion menus

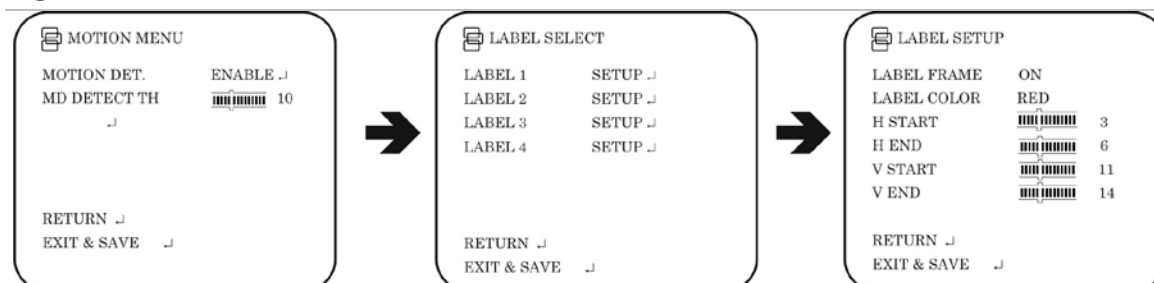

Table 7: Motion alarm menu

Menu item	Description
Motion Detec.	When enabled, you can set up four motion detection areas (Labels) on screen. For each label set the following parameters: <ul style="list-style-type: none"> • Label frame: On/Off • Label color: Blue / Pink / Yellow / Cyan / Coffee / White / Red / Green • H Start: Start of horizontal position 0 to 23 • H End: End of horizontal position 0 to 23 • V Start: Start of vertical position 0 to 23 • V End: End of vertical position 0 to 23 • Return: Press Enter to return to the previous menu • Exit & Save: Exits the menu and returns to live mode. Saves changes made
MD Detect. Th	Defines the motion or face threshold. Select a value between 0 and 127. A lower value means detection is more sensitive.
Return	Press Enter to return to the previous menu.
Exit & Save	Exits the menu and returns to live mode. Saves changes made.

Privacy menu

Privacy masks let you conceal sensitive areas (such as neighboring windows) to protect them from view on the monitor screen and in the recorded video. The masking appears as a blank colored area on screen. You can create up to 4 privacy masks.

Select the **Privacy** option from the Main menu to enter the Privacy menu.

Figure 9: The Privacy mask menus

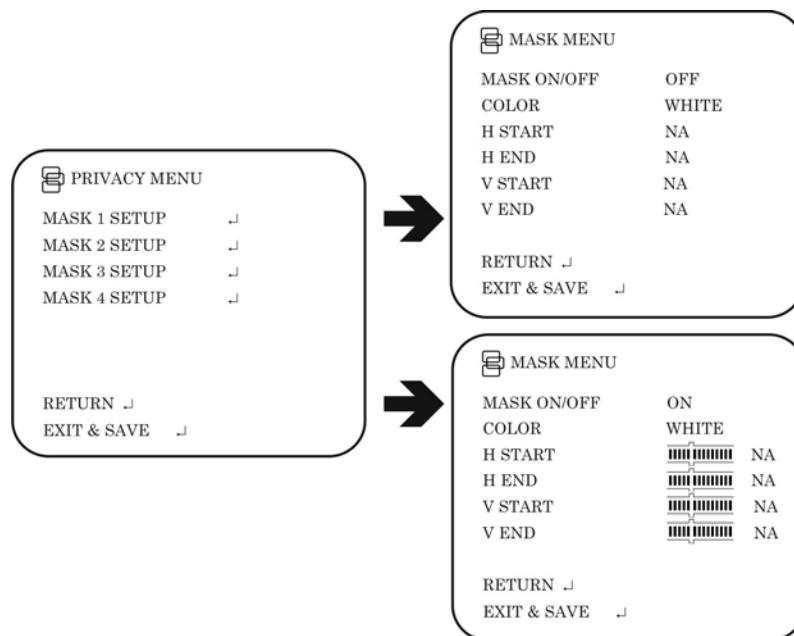

Table 8: The Privacy menu

Menu item	Description
Mask 1 Setup	When enabled, you can set up four privacy mask areas on screen.
Mask 2 Setup	For each mask set the following parameters:
Mask 3 Setup	<ul style="list-style-type: none"> • Mask: On/Off
Mask 4 Setup	<ul style="list-style-type: none"> • Color: Blue / Pink / Yellow / Cyan / Coffee / White / Red / Green • H Start: Start of horizontal position 0 to 500 • H End: End of horizontal position 0 to 500 • V Start: Start of vertical position 0 to 280 • V End: End of vertical position 0 to 280 • Return: Press Enter to return to the previous menu • Exit & Save: Exits the menu and returns to live mode. Saves changes made
Return	Press Enter to return to the previous menu.
Exit & Save	Exits the menu and returns to live mode. Saves changes made.

Picture adjustment menu

Set the camera image characteristics such as brightness, contrast, sharpness, hue, and saturation (called “Gain” here) of the picture. Their values can be set between 0 and 10.

Select the **Pict Adjust** option from the Main menu to enter the Picture menu.

Figure 10: The Picture adjustment menu

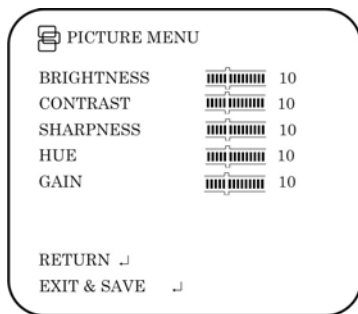

Reset camera

Use this function to restore the camera parameters to the factory defaults values. Select the **Reset** option from the Main menu to restore factory default values.

Specifications

Model	UVC-6120-1-P / UVC-6120-1-N	UVC-6120-1-P2
Lens type	C/CS-DC drive	
Power supply	24 VAC / 12 VDC	96 to 240 VAC
Current	300 mA	50 mA
Power consumption	Max. 3.6 W	Max. 4.8 W
Operating temperature	-10 to +50 °C (14 to 122 °F)	
Weight	390 g (0.85 lb.)	

Dimensions

(Units = mm)

Side view :

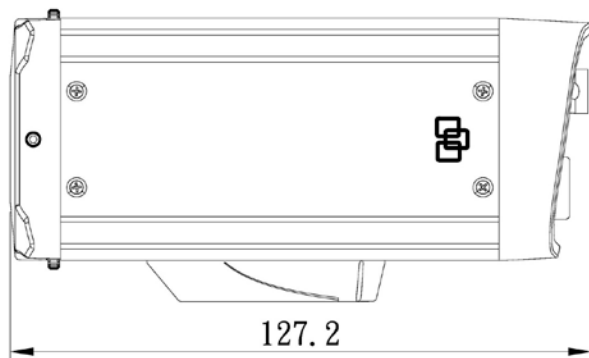

Front view :

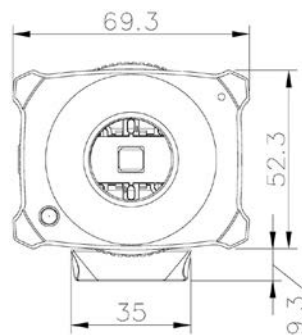

Menu Map

