

## Buried RF intrusion detection sensor

OmniTrax® is a covert outdoor perimeter intrusion detection sensor. Sensor cables buried in the ground generate an invisible detection field. Being invisible, OmniTrax offers the lowest Vulnerability to defeat (Vd) of any outdoor perimeter intrusion sensor – all while maintaining site aesthetics.

### HOW IT WORKS

OmniTrax uses ported (“leaky”) coaxial sensor cables to create an invisible electromagnetic detection field. The cables are designed with apertures in the transmit cable’s outer conductor that allows energy to escape and be detected by the corresponding parallel receive cable. OmniTrax uses a patented coded pulse signal technique to determine the exact intrusion locations, including those occurring simultaneously.

Detection is based on the intruder’s electrical conductivity, size and speed. The Probability of detection (Pd) for an upright 35 kg (77 lbs) intruder, penetrating through the detection field and moving between 5 cm (2 in) per second to 8 m (26 ft) per second is greater than 99%, with a 95% confidence. Objects weighing less than 10 kg (22 lbs) are rejected with a statistical confidence level of 95%. Any attempt to tamper with the cables, the processor or its enclosure, causes an alarm.

## Features and Benefits

- Covertly detect and locate perimeter intrusions over a distance of up to 800 m (1/2 mi) per sensor processor
- Pinpoint intrusions to  $\pm 1$  m (3.3 ft)
- Operation not affected by vegetation (including grass, shrubs and trees)
- Insensitive to wind, rain, snow, hail, sandstorms, fog, extreme temperatures, seismic vibration, acoustics, magnetic effects and blowing debris
- Completely covert – site aesthetics unchanged
- Lowest Vulnerability to defeat (Vd) of any outdoor perimeter intrusion detection sensor
- Flexible, software-based zoning (up to 50 distinct zones per processor)
- Precision sensitivity leveling (per meter)
- Power and data over sensor cables simplifies infrastructure requirements
- Communication path redundancy ensures continued perimeter protection in the event of a cable cut
- Low Nuisance Alarm Rate (NAR) and high Probability of detection (Pd)
- Software-configurable output relays simplify integration with alarm monitoring systems
- Silver Network™ compatibility enables integrated networking with FlexZone®, Senstar LM100™, UltraWave™, FP400, and XField® systems
- Sensors calibrated with Windows®-based point-and-click utility (over network or locally via USB)
- Software integration supported with a wide range of alarm monitoring systems

## REDUCE INFRASTRUCTURE COSTS

The sensor cables can carry both power and data, which greatly reduces infrastructure requirements. Power and communications are bi-directional and provide full redundancy in the event of a cable cut.

## UNIFORM DETECTION IN DIFFERENT MEDIA

Sensor cables can be direct-buried in a variety of media, including most soil types, asphalt and concrete. In soil, the cables are buried 23 cm (9 in) below the surface. In concrete, slots are cut 6 cm (2.25 in) deep. The terrain-following, volumetric detection field is typically 1 m (3.28 ft) high and 3 m (9.84 ft) wide along the entire length of the sensor cable. The sensor cables can be spaced a maximum of 2 m (79 in) and a minimum of 10 cm (4 in) apart. The maximum spacing results in a detection field typically 1 m (3.3 ft) high by 3 m (9.9 ft) wide†. Sensors can be standalone or networked, whereby sensor cables are connected together to create a continuous perimeter.

## PRECISION SENSITIVITY LEVELING

The sensor is configured and calibrated with Senstar's Windows®-based Universal Configuration Module (UCM) software. The UCM enables per-meter sensitivity leveling and includes a real-time plot mode for viewing response data. The software runs on a laptop connected via USB. If the processor is networked, remote access is also supported.

To calibrate the system, the installer simply walks along the perimeter. The UCM software automatically adjusts the sensitivity of each meter (3.3 ft) and compensates for site variations. The graded cable design ensures a uniform sensitivity along the entire length of the cable.

## FLEXIBLE ZONING

The sensor supports up to 50 distinct, software-defined detection zones. Zones enable a single sensor cable to be used across areas with different operational requirements (e.g. high-traffic areas like entrances) and to provide location data for integration with video surveillance and other security devices.

## SENSOR CABLE TYPES

The recommended sensor cable type is based on site requirements.

- OC2 cables – Uses separate transmit and receive cables and are available in 300 m (984 ft) and 400 m (1312 ft) lengths.
- SC2 cables – Uses separate transmit and receive cables and are available in 50 m (165 ft) increments up to 200 m (660 ft).

Narrow spacing reduces installation costs by allowing both cables to be placed in a single trench and is typically used in applications with space restrictions.

## ON-BOARD RELAY OUTPUTS AND DRY-CONTACT INPUTS

Each processor includes four relay outputs and two dry-contact inputs. In stand-alone mode, the function of each relay is individually configured.

In network mode, the relays may be controlled by the Security Management System (SMS) and are programmable for output type (steady, flash mode or pulse).

The dry-contact inputs serve as self-test inputs in standalone mode. In network mode, they serve as auxiliary inputs for the SMS and are programmable regarding their active state (open/closed) and resistor supervision mode.

## NETWORKING AND INTEGRATION

Alarms can be reported locally at the processor via output relays or communicated to a central location over an integrated sensor network. Communications between processors can be RS-422, single-mode fiber, multi-mode fiber, or over the sensor cables themselves. The sensor network can be polled from both ends of the perimeter, thus providing redundant data paths. If network connectivity is lost, alarms are queued internally and resent when connectivity is re-established.

The sensor network connects to the control room via EIA-422, single-mode fiber, or multi-mode fiber links. Senstar's Windows®-based Network Manager conveys alarm and status information to Senstar's Symphony™ VMS, the StarNet 2™ SMS, or to a third-party system.

For integration with third-party systems, Senstar provides an SDK that includes API documentation, a Network Manager simulator, and complete sample code. The Network Manager also supports customizable ASCII text output. For information about integrating Senstar sensors, see the Senstar Sensor Integration datasheet.

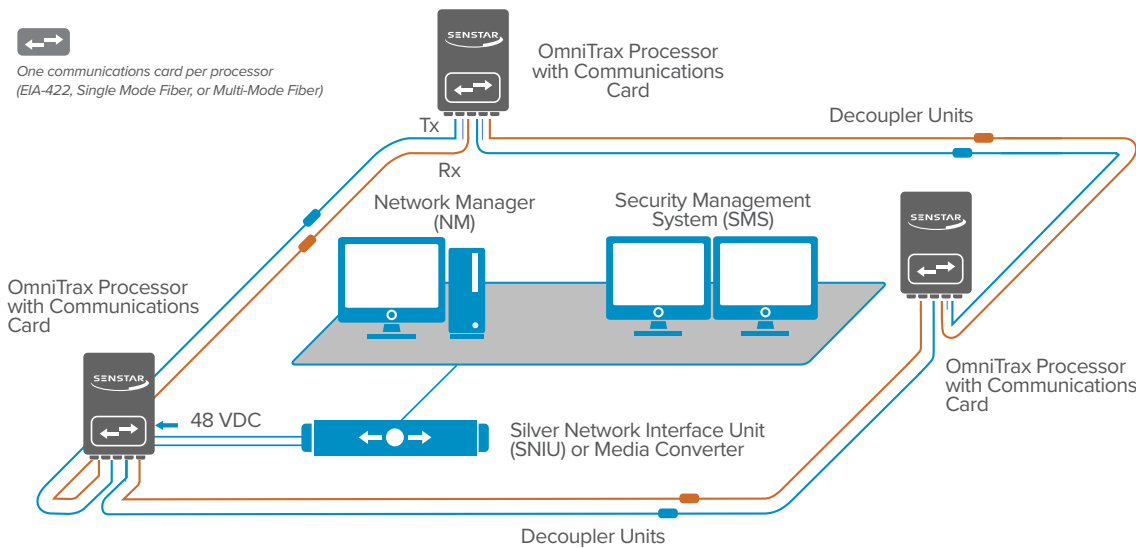

Note: No more than 5 processors may have their sensor cables electrically connected through decouplers (each group of up to 5 processors must have terminators installed at each end of the group). Data communication loops are extended across additional groups via group-to-group fiber-optic communication cables.

PART	DESCRIPTION
A4EM0101	OmniTrax processor in painted aluminum CSA/UL Type 4X enclosure, with backup battery, no auxiliary cards
00BA0301	Multi-mode fiber optic communications card
00BA0302	EIA-422 communications card
00BA0303	Single-mode fiber optic communications card
00BA0400	Relay output card (8 Form C outputs)
00BA1200	Dry contact input card (8 inputs)
A4MA0200	Telecom style protective enclosure for above ground field mounting of processor enclosure
C7SP0500	Mounting clamp for pole
A4KT1000	Lightning protection kit. Recommended in areas with a high incidence of lightning. Works with SC2 and OC2 cable. One kit handles two cable pairs attached to one OmniTrax processor.

PART	DESCRIPTION	
A0KT1500	Connector tool kit, includes crimp tool and cable preparation tools for SC2 cables	
A4KT0200	Connector tool kit, includes crimp tool and cable preparation tools for OC2 cables	
A3FG0301	SC2 cables (2), 50 m	<i>All cables include 20 m of lead-in, 4 TNC connectors, 20 ferrite beads, and two 305 m rolls of underground warning tape.</i>
A3FG0302	SC2 cables (2), 100 m	
A3FG0304	SC2 cables (2), 150 m	
A3FG0311	SC2 cables (2), 200 m	
A4FG0120	OC2 cables (2), 400 m	<i>All cables include 20 m of lead-in, 6 TNC connectors, 42 ferrite beads, and three 305 m rolls of underground warning tape.</i>
A4FG0121	OC2 cables (2), 300 m	
A4KT1202	SC2 cable standalone (power blocking) decoupler kit	OC2 cable standalone (power blocking) decoupler kit
A4KT1102	OC2 cable standalone (power blocking) decoupler kit	
A4KT1201	SC2 cable network (power passing) decoupler kit	OC2 cable network (power passing) decoupler kit
A4KT1101	OC2 cable network (power passing) decoupler kit	
A4KT1302	SC2 cable terminator kit A4EM0100	OC2 cable terminator kit
A4KT1304	OC2 cable terminator kit	
A4EM0200	100W outdoor-rated 48V DC power supply	
00CD0100	Universal documentation package on USB, includes Universal Configuration Module (UCM)	

# Technical Specifications

## PROCESSOR SPECIFICATIONS

### Main features

- Covertly detect and locate perimeter intrusions over a distance of up to 800 m (1/2 mi) per sensor processor
- Pinpoint intrusions within ±1 m (±3.3 ft)
- Up to 50 software-defined zones per processor
- Probability of detection (Pd): Optimized for the detection of an upright 35 kg (77 lbs) or larger person moving between 5 cm (2 in) to 8 m (26 ft) per second, with a probability of detection of 99% with a 95% confidence
- Calibration and operating parameters configured via UCM software

### Environmental specifications

- Temperature: -40 to 70 °C (-40 to +158 °F)
- Humidity: 95% (non-condensing)

### Electrical specifications

- Input power: 12 to 48 VDC
- Consumption: Less than 9W
- Optional internal 5 Ah battery backup
- Up to 5 processors may share a common power supply
- Lightning protection: Tranzorb and non-radioactive gas discharge devices on all I/O ports

### Physical specifications

- Processor on a base plate in a white aluminum CSA/UL Type 4X enclosure:
  - Dimensions (H/W/D): 40 x 23.5 x 16.5 cm (15.75 x 9.25 x 6.5 in)
  - Weight: 4.9 kg (10.8 lbs) (without optional battery)
  - 4 TNC-F bulkhead connectors for sensor cable attachment.
  - 4 general cable entry points with compression glands (includes filter plugs)
- Optional protective telecom enclosure:
  - Dimensions (H/W/D): 98.4 x 42.5 x 27.3 cm (38.8 x 16.8 x 10.8 in)
  - Color: Light green enamel over steel
  - Protection: IP33

### Supervision/self-test features

- Monitoring of the sensor cable to detect opens, shorts and grounding
- Enclosure tamper switch
- Monitoring of critical processor parameters

### RELAY OUTPUTS AND AUXILIARY INPUTS

- 4 Form C output relays, 1.0A at 30VDC
- Relays can be controlled locally or over the network
- Function of each relay can be assigned based on requirements
- Assignable functions under local control include: alarm, supervision, door tamper, power fail and fail-safe
- Activation time programmable from 0.125 to 10 seconds
- In network mode, relays programmable for activation type and timing

- Two self-test inputs, one per cable side, become auxiliary dry contact inputs when processor is operating in network mode
- Auxiliary inputs are programmable for supervision type, resistor value(s) and filtering

### OPTIONAL NETWORK CARDS

- EIA-422 network card with A and B side Tx/Rx connections for Silver networks
- Multi-mode fiber optic network card with ST connectors (820 nm) to support A and B side Tx/Rx connections for Silver network. Allows distances of up to 2.2 km (7,200 ft)
- Single-mode fiber optic network card with ST connectors (9/125 single-mode fiber, 1310 nm) with A and B side Tx/Rx connections for Silver Network. Allows distances of up to 10 km (32,000 ft)

### OPTIONAL I/O CARDS

- Processor can accept one optional input or output card in addition to comm card
- Relay output card: 8 Form C relay outputs (1.0 A, 30 VDC max)
- Universal input card: 8 inputs with configurable thresholds and supervision

### SENSOR CABLES

- Different cables depending on site requirements (OC2 and SC2)
- Two pairs of sensor cable per processor
- Contiguous graded design with lead-in and active cable
- Lead-in length: 20 m (66 ft) (OC2)
- Active cable lengths:
  - OC2: 400 m (1312 ft) or 300 m (984 ft)
  - SC2: 50, 100, 150 or 200 m (164, 328, 492 or 656 ft)
- Cable jacket diameter:
  - OC2: 12.07 mm (0.475 in)
  - SC2: 8.0 mm (0.315 in)

### CABLE ACCESSORIES

- Standalone and network decouplers
- Terminator kits/connector tool kits/cable repair kits
- Ferrite beads, connectors, and marker tape:
  - OC2: 6 TNC connectors, 42 ferrite beads
  - SC2: 4 TNC connectors, 10 ferrite beads

### UNIVERSAL CONFIGURATION MODULE (UCM) SOFTWARE

- Windows®-based, point-and-click interface
- Communicates with processor via local USB connection or over network
- Precise sensitivity leveling (per meter)
- View real-time sensor data and save for later analysis

### REGULATORY COMPLIANCE

- Safety: IEC 60950-1, CSA 60950-1-03, SELV supplied, Class 1
- RF Emissions and Susceptibility: CE, FCC (Part 15, Subpart B), Industry Canada
- RoHS2
- CPNI: Approved for U.K. government use



† Actual field size depends on burial depth, burial medium, cable separation and sensor threshold settings.