



## Product Data Sheet

# UVP-N120P-36X-P

UltraView H.264 4CIF 36X Pan/Tilt/Zoom Camera

### Overview

UTC Fire and Security introduces the next generation of IP PTZ technology with the addition of the new 4CIF H.264 based IP solution for improved image quality in optical and digital zoom.

### PTZ technology

This series of H.264 PTZ solutions makes use of the latest available technology to allow for installation of the dome in a wide range of applications and environmental conditions, with standard outdoor pendant housings achieving the IP66 rating and a flush mount indoor housing. This latest PTZ solutions is available with the progressive scan image technology.

### Compression & streaming

The UltraView IP PTZ camera utilize H.264 compression technology with dual-stream capability, making it easy to manage the camera's bandwidth usage. Fully designed to adhere to PSIA and ONVIF open communication standards as well as supporting a CGI command set, the camera allow for simple integration into any IP system. Video streams can be set for high or low bandwidth and images can be streamed for live viewing or sent to a designated recording location.

### Additional Features

Featuring an integrated browser and available SDHC memory card storage capabilities, UltraView IP PTZ camera simplify remote, live monitoring/playback of edge-recorded video. Recording on the memory card can be done by manual- or alarm-recording.



### Standard Features

- 1/4 inch progressive scan CCD
- H.264 Advanced compression technology
- ONVIF/ PSIA and CGI compliant
- Models include 2 alarm inputs and 2 relay output
- 256 preset positions, 8 preset tours, and 4 shadow tours
- 360° Endless Rotation
- 540°/s Pan Preset Speed and 400°/s Tilt Preset Speed
- Auto-Flip image
- Built-in SD/SDHC slot

# UVP-N120P-36X-P

UltraView H.264 4CIF 36X Pan/Tilt/Zoom Camera

## Specifications

### General Specifications

- Pan travel 360° continuous
- Tilt travel -5° - 185° (Auto Flip)
- Manual pan speed 0.1° to 300°/sec
- Manual tilt speed 0.1° to 240°/sec
- Protocols RS-485, Pelco-P, Pelco-D
- Dimensions: Ø 220×262mm
- Weight: 5kg

### Video Encoder

- H.264 compression
- Dual streaming supported
- Digital resolution 4CIF, DCIF, 2CIF, CIF and QCIF
- Digital frame rate Up to 25 frames/sec
- Protocols: TCP/IP, HTTP, DHCP, DNS, RTP / RTCP, PPPoE

### Camera Specifications

- Image Sensor: 1/4" Sony EXVIEW HAD progressive scan CCD
- Zoom: Optical 36X; 12X Digital
- WDR: 128x (On / off / auto)
- Image Stabilization : On/Off
- Angle of View (H): 57.8° (wide) to 1.7° (tele)
- Lens: F=3.4 mm (wide) to 122 mm (tele); F1.6 to F4.5
- Synchronization: Internal / Line Lock
- Sensitivity: 1.4Lux/F1.6 (Color), 0.01Lux/F1.6(B&W)
- Electronic Shutter Speed: 1/50 to 1/10.000 sec
- Operating Voltage: 24 VAC +/- 4 VAC
- Power consumption: 15W Indoor and 30W (Heater On)
- Environmental: IP66 standard (Outdoor housing)
- Operating temperature: -30°C to 65°C (Outdoor housing)
- S/N Ratio: Better than 50dB
- Day & Night: IR Cut Filter automatic
- Iris/focus: automatic
- Integrated sunshield
- Media: SDHC card up to 32GB
- Masking: 24 privacy masks programmable; a maximum of 8 zones can be masked simultaneously on the same video screen
- Preset and Tour Titels

## Diagram

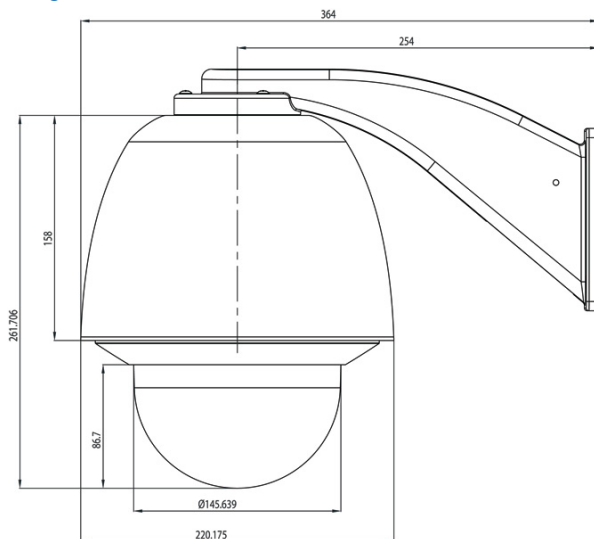

## Ordering Information

UVP-N120P-36X-P

UltraView H.264 4CIF 36X Pan/Tilt/Zoom Camera, Pendant mount version

