



Product Data Sheet

UVD-6120VE-2-P

UltraView™ 650TVL Outdoor Rugged Dome

Introduction

The UltraView™ 650TVL outdoor rugged dome camera is a video surveillance camera, which provides a crisp 650TVL high resolution and excellent 0.08 lux sensitivity.

Furthermore, its Adaptive Tone Reproduction (ATR) function improves contrast in bright/dark areas of the image in single shutter exposure. Its Digital Image Stabilizer (DIS) function suppresses the image shaking that can occur when cameras are mounted outdoors, in higher locations, or areas subject to vibration.

The UltraView™ 650TVL outdoor rugged dome camera is designed for most indoor and outdoor circumstance with its advantages of high resolution and well-balanced spectral sensitivity, without compromising saturation and color accuracy. The IR cut filter along with intelligent algorithms optimize the Day/Night switch performance and eliminate annoying back-and-forth cycles under challenging lighting conditions.

The camera is designed for both indoor and outdoor applications with its 3-axis gimbal bracket, removable IR-cut filter, varifocal lens, weatherproof, vandal-resistant rugged enclosure, and extended cold-start operating temperature down to -30°C.

A variety of UltraView dome mounts are available to install the camera to meet the needs of the installation.



Standard Features

- 650TVL Outdoor Rugged Dome
- 1/3" EXview HAD CCD II
- 0.08 lux @ F1.2 (50IRE)
- 2.8-10mm varifocal lens
- ATR, 2DNR, HLC
- True Day/Night
- Motorized IR Cut Filter
- 24 VAC / 12 VDC
- Vandal resistant
- Outdoor IP66 rated

UVD-6120VE-2-P

UltraView™ 650TVL Outdoor Rugged Dome

Specifications

Camera

- Sensor Size: 1/3
- Sensor Scan: Interlaced
- Sensor Type: EXview HAD CCD? / SONY
- DSP: Effio-E / SONY
- Total pixels (H x V): NTSC:1028(H) x 508(V) / PAL:1028(H) x 596(V)
- Effective pixels (H x V): NTSC:976 (H) x 494(V) / PAL:976 (H) x 582(V)
- Resolution (color): 650TVL
- Resolution (B&W): 660TVL
- Synchronization system: Internal
- Electronic shutter: Auto 1/60 (1/50) ~1/100,000 sec.
- Digital S/N ratio: 52dB (AGC OFF)
- Video signal: 1.0 Vp-p / 75 ohm composite
- Certification: FCC,CE

Lighting performance

- Wide Dynamic Range: ATR
- WDR in dB: 58
- Digital Noise reduction: 2DNR
- Highlight compensation (HLC): Yes
- Day/Night: True Day/Night
- Motorized IR Cut Filter: Yes
- Color sensitivity: 0.1 lux@F1.2 (50IRE)
- B/W sensitivity: 0.08 lux@F1.2 (50IRE)

Housing

- Camera type: Dome
- IP rating: IP66
- Outdoor: Yes
- Rugged: Yes
- Vandal proof: Yes

Lens

- Control type: DC
- Varifocal: Yes
- Focal length: 2.8-10mm
- F-stop: F1.2
- Autoiris: Yes

Power consumption

- PSU included: No
- Voltage Input: 12VDC / 24VAC
- Current: 400 mA (Heater on)
- Power Consumption: 9.6W (Heater on)

Camera analytics

- Motion Detection: Yes

- Privacy Masking: Yes

Alarm

- Alarm Input: No
- Alarm Output: No

Mechanical / Environmental

- Dimensions: 133 x 105 mm (5.2 x 4.1 in.)
- Weight: 1130 g (2.49 lb.)
- Operating Temperature: -30 to 50°C (22 to 122°F)
- Storage Temperature: -20 to 70°C (-4 to 158°F)

Diagram

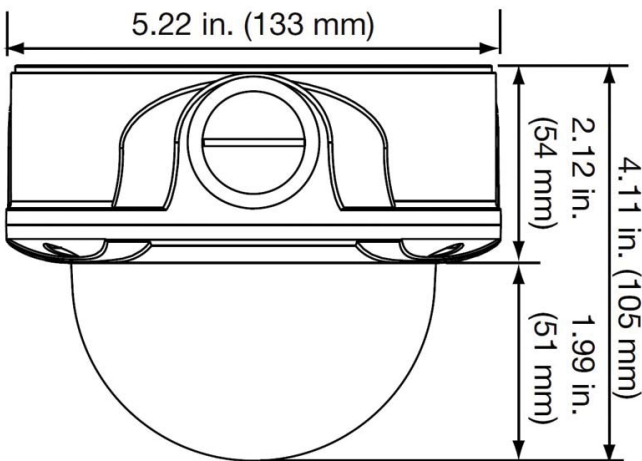

Ordering Information

UVD-6120VE-2-P

UltraView™ 650TVL Outdoor Rugged Dome

