



## Product Data Sheet

# UVC-6130-1-P

UltraView™ 650TVL WDR Box Camera

### Introduction

---

The UltraView™ 650TVL WDR box camera is a video surveillance camera, which provides a crisp 650TVL high resolution and excellent 0.01 lux sensitivity.

Using the latest CCD sensors and DSP technology, the UltraView™ WDR Cam offers both 650TVL resolution and 0.01 lux low light sensitivity at the same time.

Based on dual shutter Wide Dynamic Range technology, the camera can acquire natural images with fewer blown-out highlights and hidden shadows under the most difficult lighting conditions. Its Adaptive Tone Reproduction –EX (ATR-EX) function utilizes a single shutter exposure frame with precise calculations leveraging the camera's powerful DSP.

The UltraView™ box camera is designed for most indoor and outdoor circumstance with its advantages of high resolution and well-balanced spectral sensitivity, without compromising saturation and color accuracy. The IR cut filter along with intelligent algorithms optimize the Day/Night switch performance and eliminate annoying back-and-forth cycles under challenging lighting conditions.



### Standard Features

---

- 650TVL WDR box camera
- 1/3" Super HAD CCD II
- 0.5 lux @ F1.2 (50IRE)
- WDR, ATR, 2DNR, 3DNR, HLC
- True Day/Night
- Motorized IR Cut Filter
- 24 VAC / 12 VDC
- Fits existing housings, brackets & lenses

# UVC-6130-1-P

## UltraView™ 650TVL WDR Box Camera

### Specifications

#### Camera

- Sensor Size: 1/3
- Sensor Scan: Interlaced
- Sensor Type: Super HAD CCD II / SONY
- DSP: Effio P / SONY
- Total pixels (H x V): NTSC:1020(H) x 508(V) / PAL:1028(H) x 596(V)
- Effective pixels (H x V): NTSC:976 (H) x 494(V) / PAL:976 (H) x 582(V)
- Resolution (color): 650TVL
- Resolution (B&W): 660TVL
- Synchronization system: Internal
- Electronic shutter: Auto 1/60 (1/50) ~ 1/100 000 sec
- Digital S/N ratio: 52dB (AGC Off)
- Video signal: 1.0 Vp-p / 75 ohm composite
- Certification: FCC,CE

#### Lighting performance

- Wide Dynamic Range: ATR+WDR
- WDR in dB: 112
- Digital Noise reduction: 2DNR + 3DNR
- Highlight compensation (HLC): Yes
- Day/Night: True Day/Night
- Motorized IR Cut Filter: Yes
- Color sensitivity: 0.55 lux@F1.2 (50IRE)
- B/W sensitivity: 0.5 lux@F1.2 (50IRE)

#### Housing

- Camera type: Box
- Outdoor: No
- Rugged: No
- Vandal proof: No

#### Lens

- Mount type: C/CS
- Control type: DC
- Varifocal: Yes
- Autoiris: Yes

#### Power consumption

- PSU included: No
- Voltage Input: 12VDC / 24VAC
- Current: 12VDC / 245mA - 24VAC / 240mA
- Power Consumption: 12VDC / 2.9W - 24VAC / 2.4W

#### Audio

- Audio: yes
- Built-in Microphone: Yes

#### Camera analytics

- Motion Detection: Yes
- Privacy Masking: Yes

#### Alarm

- Alarm Input: No
- Alarm Output: No

#### Mechanical / Environmental

- Dimensions: 127.2 x 69.3 x 52.3 mm (5.0 x 2.7 x 2.0 in.)
- Weight: 415 g (0.9 lb.)
- Operating Temperature: -10 to 50°C (14 to 122°F)
- Storage Temperature: -20 to 70°C (-4 to 158°F)

### Diagram

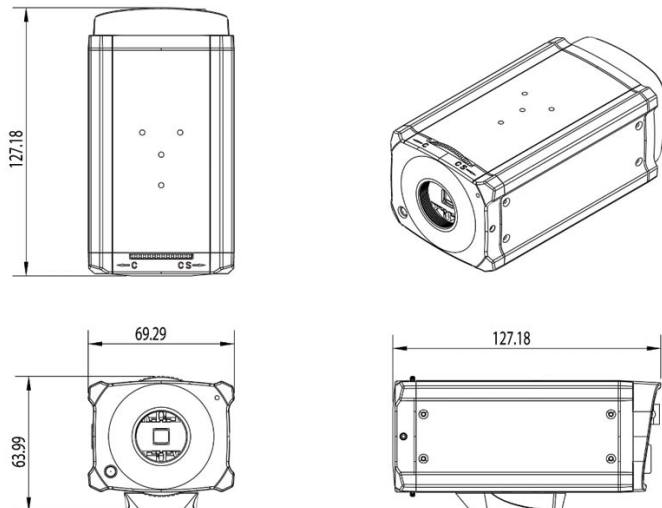

### Ordering Information

UVC-6130-1-P

UltraView™ 650TVL WDR Box Camera

