



Product Data Sheet

UVC-6120-1-P2

UltraView™ 650TVL Box Camera

Introduction

The UltraView™ 650TVL box camera is a video surveillance camera, which provides a crisp 650TVL high resolution and excellent 0.08 lux sensitivity. Furthermore, its Adaptive Tone Reproduction (ATR) function improves contrast in bright/dark areas of the image in single shutter exposure.

Its Digital Image Stabilizer (DIS) function suppresses the image shaking that can occur when cameras are mounted outdoors, in higher locations, or areas subject to vibration.

The UltraView™ box camera is designed for most indoor and outdoor circumstance with its advantages of high resolution and well-balanced spectral sensitivity, without compromising saturation and color accuracy. The IR cut filter along with intelligent algorithms optimize the Day/Night switch performance and eliminate annoying back-and-forth cycles under challenging lighting conditions.



Standard Features

- 650TVL box camera
- 1/3" EXview HAD CCD II
- 0.08 lux @ F1.2 (50IRE)
- ATR, 2DNR, HLC
- True Day/Night
- Motorized IR Cut Filter
- 96-240V mains power
- Fits existing housings, brackets & lenses

UVC-6120-1-P2

UltraView™ 650TVL Box Camera

Specifications

Camera

- Sensor Size: 1/3
- Sensor Scan: Interlaced
- Sensor Type: Super HAD CCD II / SONY
- DSP: Effio E / SONY
- Total pixels (H x V): NTSC:1028(H) x 508(V) PAL:1028(H) x 596(V)
- Effective pixels (H x V): NTSC:976 (H) x 494(V) PAL:976 (H) x 582(V)
- Resolution (color): 650TVL
- Resolution (B&W): 660TVL
- Synchronization system: Internal
- Electronic shutter: Auto 1/60 (1/50) ~1/100,000 sec
- Digital S/N ratio: 52dB (AGC Off)
- Video signal: 1.0 Vp-p / 75 ohm composite
- Certification: FCC,CE

Lighting performance

- Wide Dynamic Range: ATR
- WDR in dB: 58
- Digital Noise reduction: 2DNR
- Highlight compensation (HLC): Yes
- Day/Night: True Day/Night
- Motorized IR Cut Filter: Yes
- Color sensitivity: 0.1 lux@F1.2 (50IRE)
- B/W sensitivity: 0.08 lux@F1.2 (50IRE)

Housing

- Camera type: Box
- Outdoor: No
- Rugged: No
- Vandal proof: No

Lens

- Mount type: C/CS
- Control type: DC
- Varifocal: Yes
- Autoiris: Yes

Power consumption

- PSU included: No
- Voltage Input: 96VAC to 240VAC
- Current: 110VAC / 41mA - 220VAC / 28mA
- Power Consumption: 110VAC / 1.9W - 220VAC / 2.2W

Audio

- Audio: yes
- Built-in Microphone: Yes

Camera analytics

- Motion Detection: Yes
- Privacy Masking: Yes

Alarm

- Alarm Input: No
- Alarm Output: No

Mechanical / Environmental

- Dimensions: 127.2 x 69.3 x 52.3 mm (5.0 x 2.7 x 2.0 in.)
- Weight: 545 g (1.2 lb.)
- Operating Temperature: -10 to 50°C (14 to 122°F)
- Storage Temperature: -20 to 70°C (-4 to 158°F)

Diagram

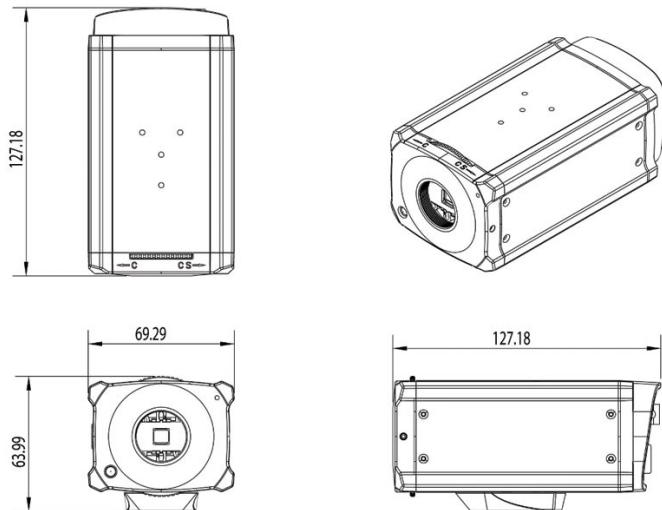

Ordering Information

UVC-6120-1-P2

UltraView™ 650TVL Box Camera

