



Product Data Sheet

TVD-M3210V-2-P

3 MPX Full HD Indoor Dome ONVIF/PSIA

Overview

TruVision™ IP and IP megapixel compact dome cameras bring state-of-the-art, high definition pictures to the mass video surveillance market. With a wide variety of camera resolutions ranging from standard resolution through 3 megapixel, these IP cameras represent a flexible video surveillance device to meet any need. Equipped with advance technology and signal processing capabilities, the effectively capture video under challenging conditions.

Compression & streaming

These TruVision cameras utilize H.264 compression technology with dual-stream capability, making it easy to manage the camera's bandwidth usage.

Fully designed to adhere to PSIA and ONVIF open communication standards as well as supporting a CGI command set, these cameras allow for simple integration into any IP system. Video streams can be set for high or low bandwidth and images can be streamed for live viewing or sent to a designated recording location.

Additional Features

Featuring an integrated browser and available SDHC memory card storage capabilities, TruVision IP and IP Megapixel cameras simplify remote, live monitoring/playback of edge-recorded video and audio. Recording on the memory card also provides a level of redundancy in case of unforeseen network disruptions.

Form Factor

The standard compact dome version of the TruVision IP & Megapixel range provides a vandal proof indoor solution up to three megapixel. Available with a wide range of appropriate brackets and wall mounts, these cameras can provide a solution to the most advanced of needs. Typical application areas are places where crisp images are required such as retail, banking, airports, gaming or mass transit.



Standard Features

- Maximum Resolution: 2048x1536 @ 12.5 fps
- Maximum Real Time Resolution: 1920x1080 @ 25 fps (Full HD)
- Designed to PSIA and ONVIF open standards
- H.264 compression with dual streaming functionality
- Edge recording up to 32GB SDHC card
- 1/2.5" CMOS image sensor
- Digital D/N
- 0.6 Lux (Color)
- Motion detection (396 zones)
- Privacy masking (396 zones)
- 2 Input/Output

TVD-M3210V-2-P

3 MPX Full HD Indoor Dome ONVIF/PSIA

Specifications

Camera

- Sensor: 3MPx 1/2.5" Progressive Scan CMOS
- Day/Night: Digital D/N
- IP Compression/Standard: H.264 PSIA/ONVIF
- Maximum Resolution (@ FPS): 2048 X 1536 (12.5 FPS)
- Maximum Real Time Resolution (@ FPS): 1920 X 1080 (25 FPS)
- Dual Streaming: Yes
- Video Bit Rate: 32 Kbps to 8 Mbps, adjustable
- Sensitivity: 0.6Lux (Color)
- S/N Ratio: > 50 dB
- Auto Exposure (shutter): 1/25s to 1/100,000s
- Composite Output (BNC): PAL, 1.0 Vp-p @ 75 ohm (NTSC Selectable)
- Lens : 2.7-9mm, F1.4 Autoiris

Electrical

- Voltage Input: 12 VDC PoE (IEEE 802.3af)
- Power Consumption: 4.5 Watts
- I/O Connection: Terminal Plug RJ46

Network

- Network Protocols: TCP/IP, HTTP, DHCP, DNS, DDNS, RTP/RTCP, PPPoE, SMTP, NTP
- Ethernet/IP: CoS 802.1 p/Q, QoS, IPv4
- PoE IEEE: 802.3af

Local Storage

- Media: SDHC (Secure locked card slot)
- Capacity: Up to 32GB

Audio G.711

- Input: 1 ch. 3.5 mm audio interface (2.0 - 2.4 Vp-p, 1 kOhm)
- Output: 1 ch. 3.5 mm audio interface (Line level, 600 Ohm)
- Audio Bitrate: 16Kbps

Camera Analytics

- Motion Detection: On-board 396 zones per camera
- Privacy Masking: On-board 396 zones per camera

Alarm

- Alarm Input: 2
- Alarm Output: 2 Form C alarm relay
- I/O Connection: Terminal Plug

Mechanical/ Environmental

- Dimensions: 140 x 120 mm (5.5 x 4.7 in.)
- Weight: 1.3kg (2.8lbs)
- Storage Temperature: -20 to 70°C (-4 to 158°F)
- Operating Temperature: -10°C to 60°C (14 to 140°F)

Diagram

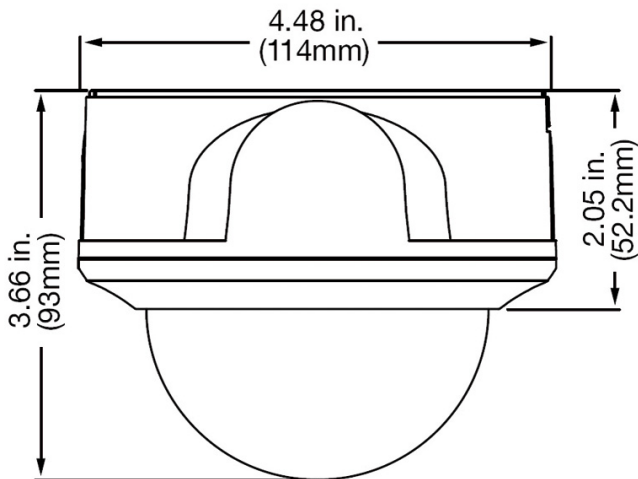

Environmental Rating: Indoor Vandal-Resistant

PC Requirements

- Intel-based PC: 1 Ghz or faster
- Memory: 1 GB RAM
- Operating System: Windows® XP, Vista or 7
- CGI: Direct X 9.0 or later
- Browser: Microsoft Internet Explorer 6.0 or later

Ordering Information

TVD-M3210V-2-P

3 MPX Full HD Indoor Dome ONVIF/PSIA

