



Product Data Sheet

TVD-5125TE-3-P

TruVision™ 550TVL IR Dome Camera

Introduction

The TruVision™ 550 TVL IR dome camera supplies the most essential and common features with the mainstream specification in market, such as 550 TVL resolution, good sensitivity (0.5 lux) and IR illumination for enhanced low-light performance. Customers do not need to compromise video quality or break their budgets. TruVision series cameras are general-purpose high resolution cameras with full features for different video surveillance applications.



Standard Features

- 550TVL IR dome camera
- 1/3" CMOS Sensor
- 3.6 mm fixed lens
- 0 lux with IR on
- 10m IR illumination
- Motorized IR cut filter
- 12 VDC
- Outdoor IP66 rated

TVD-5125TE-3-P

TruVision™ 550TVL IR Dome Camera

Specifications

Camera

- Sensor Size: 1/3
- Sensor Scan: Interlaced
- Sensor Type: PC1089K CMOS / Pixel plus
- DSP: PC1089K CMOS / Pixel plus
- Total pixels (H x V): NTSC/PAL: 762 (H) x 504(V)
- Effective pixels (H x V): NTSC/PAL: 728 (H) x 488 (V)
- Resolution (color): 550TVL
- Resolution (B&W): 560TVL
- Synchronization system: Internal
- Electronic shutter: Auto 1/60 (1/50) ~1/100,000 sec
- Digital S/N ratio: >50 dB
- Video signal: 1.0 Vp-p / 75 ohm composite
- Certification: FCC,CE

Lighting performance

- Day/Night: True Day/Night
- Motorized IR Cut Filter: Yes
- Color sensitivity: 1.5 lux@F1.2 (50IRE)
- B/W sensitivity: 1.5 lux@F1.2 (50IRE)
- IR sensitivity: 0 Lux with IR on
- IR Range: 15m
- IR Wavelength: 850nm
- B/W trigger: 7lux ± 3lux IR ON / OFF
- IR trigger: 7lux ± 3lux IR ON / OFF

Housing

- Camera type: Dome
- IP rating: IP66
- Outdoor: No
- Rugged: No
- Vandal proof: No

Lens

- Mount type: Fixed
- Control type: Man
- Varifocal: No
- Focal length: 3.6mm
- F-stop: F1.2
- Autoiris: No

Power consumption

- PSU included: No
- Voltage Input: 12VDC
- Current: 180 mA(IR on)
- Power Consumption: 2W (Max)

Diagram

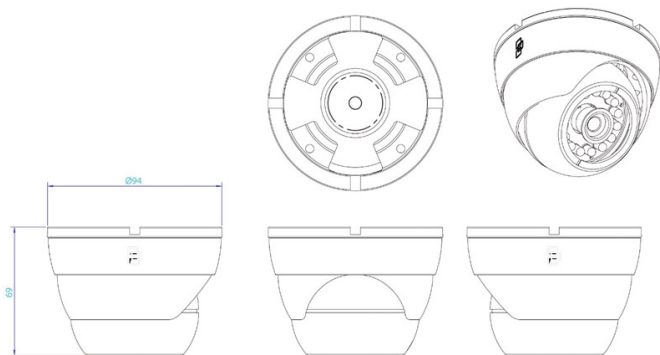

Camera analytics

- Motion Detection: No
- Privacy Masking: No

Alarm

- Alarm Input: No
- Alarm Output: No

Mechanical / Environmental

- Dimensions: 94 x 70 mm (3.7 x 2.76 in.)
- Weight: 320 g (0.7lb.)
- Operating Temperature: -10 to 50°C (14 to 122°F)
- Storage Temperature: -20 to 70°C (-4 to 158°F)

Ordering Information

TVD-5125TE-3-P

TruVision™ 550TVL IR Dome Camera

