

# TVP-WMB

TruVision PTZ dome wall mount bracket

## Overview

---

The TVP-WMB is a wall mount bracket that can be used in combination with various TruVision PTZs. It can be combined with corner or pole mount accessories to facilitate various installation types.



## Details

---

- Wall mount bracket
- Compatible with corner mount and pole mount accessories
- Safety lanyard included for secure PTZ installation
- Cable management within the bracket

# TVP-WMB

TruVision PTZ dome wall mount bracket

## Technical Specifications

### General

Bracket type	Camera
Bracket mounting part	Mounting bracket
Camera support type	PTZ camera
Mount type	Wall mount
Cable Management	Yes

### Physical

Physical dimensions	128 × 105 × 303.45 mm 5.04 × 4.13 × 11.95 in.
Net weight	945 g 2.08 lbs.

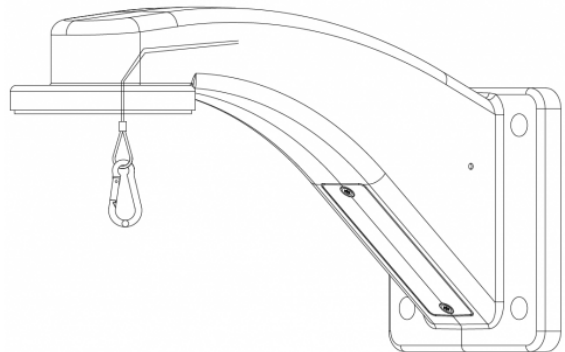

As a company of innovation, UTC Technologies reserves the right to change product specifications without notice. For the latest product specifications, visit UTC Technologies online or contact your sales representative.